



-  Handleiding
-  Manual
-  Handbuch
-  Manuel

LW-FE Friso Eco



LIGHTWELL

	Productnaam	LEDs	Vermogen	Kleurweergave	Stroomvoorziening	Installatie hoogte	Gewicht
	Friso Eco	8-32 pcs	10W-50W	3000K/4000K/Custom	200-240V~50/60Hz	4-6m	8 kg

	Name Product	LEDs	Power	Colour rendering	Power supply	Installation height	Weight
	Friso Eco	8-32 pcs	10W-50W	3000K/4000K/Custom	200-240V~50/60Hz	4-6m	8 kg

	Name Produkt	LEDs	Leistung	Farbwiedergabe	Stromversorgung	Installationshöhe	Gewicht
	Friso Eco	8-32 pcs	10W-50W	3000K/4000K/Custom	200-240V~50/60Hz	4-6m	8 kg

	Nom Produit	LEDs	Puissance	T° de couleur	Alimentation	Hauteur d'installation	Poids
	Friso Eco	8-32 pcs	10W-50W	3000K/4000K/Custom	200-240V~50/60Hz	4-6m	8 kg

A1 Friso Eco

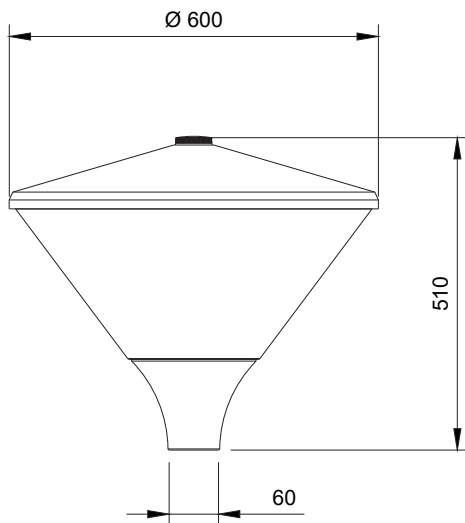

-  Geprojecteerde oppervlakte: 0,24 m²
-  Frontal Projected Area: 0,24 m²
-  Querschnittsfläche: 0,24 m²
-  Surface frontale projetée: 0,24 m²

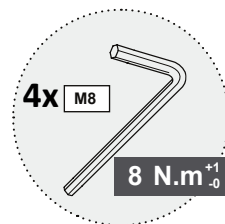
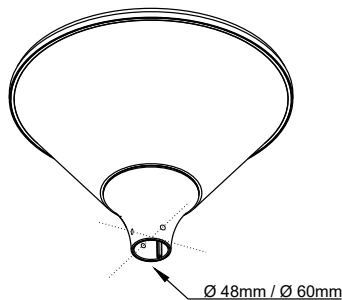

										
---	---	---	---	---	---	---	---	---	---	---

IK
10

B1 Friso Eco

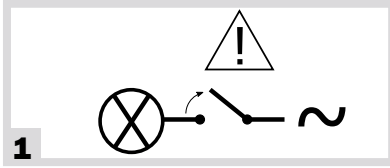

2

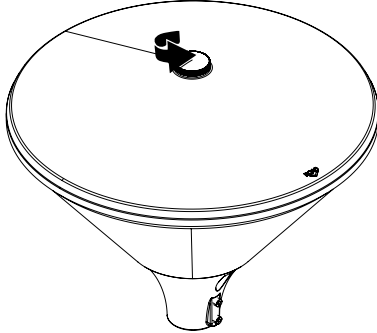



-   1 + 2 Openen van het armatuur.
-   1 + 2 Opening the fixture.
-   1 + 2 Die Leuchte öffnen.
-   1 + 2 Ouverture de l'armature.

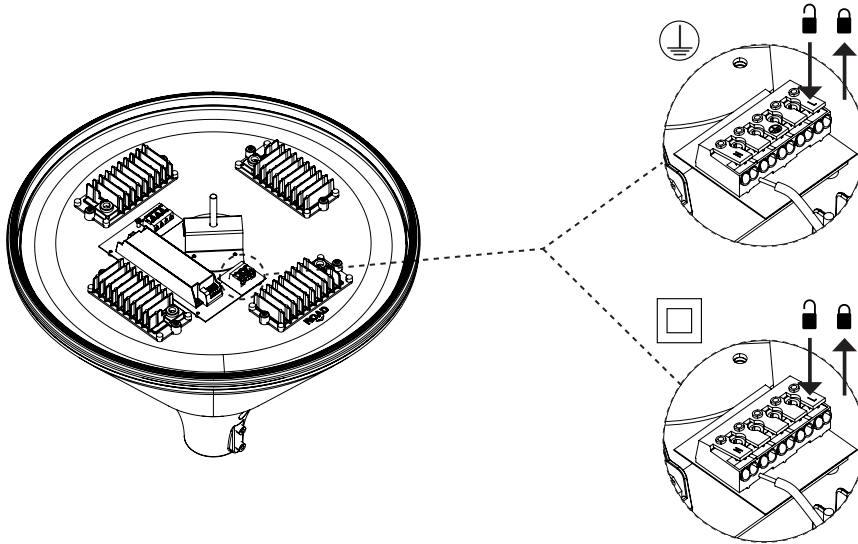

3







B2







  Klasse I: De externe kabel moet 3G 1,5 mm² / 3G 2,5 mm² en een minimale doorsnede 1,0 mm² zijn. De kabel moet voldoen aan de norm 60245 IEC 57.



  Klasse II: De externe kabel moet 3G 1,5 mm² / 3G 2,5 mm² en een minimale doorsnede 1,0 mm² zijn. De kabel moet voldoen aan de norm 60245 IEC 57.



  Class I: The external cable must be 3G 1,5 mm² / 3G 2,5 mm² and a minimum cross section 1,0 mm². The cable must comply with the 60245 IEC 57 standard.

  Class II: The external cable must be 3G 1,5 mm² / 3G 2,5 mm² and a minimum cross section 1,0 mm². The cable must comply with the 60245 IEC 57 standard.

  Klasse I: Das externe Kabel muss 3G 1,5 mm² / 3G 2,5 mm² und einen Mindestquerschnitt von 1,0 mm² haben. Das Kabel muss der Norm 60245 IEC 57 entsprechen.

  Klasse II: Das externe Kabel muss 3G 1,5 mm² / 3G 2,5 mm² und einen Mindestquerschnitt von 1,0 mm² haben. Das Kabel muss der Norm 60245 IEC 57 entsprechen.

  Classe I: Le cable externe doit être 3G de 1,5 mm² / 3G 2,5 mm² et une section minimale de 1,0 mm². Le cable doit être conforme à la norme 60245 IEC 57.

  Classe II: Le cable externe doit être 3G de 1,5 mm² / 3G 2,5 mm² et une section minimale de 1,0 mm². Le cable doit être conforme à la norme 60245 IEC 57.

E

1. Het armatuur mag niet worden ondergedompeld in water of in de buurt van een vuur worden geïnstalleerd.
2. Het armatuur moet worden geïnstalleerd door een gekwalificeerde elektricien in overeenstemming met de nieuwste IEEE elektrische voorschriften.
3. Zorg ervoor dat de deksel/kap van het armatuur goed is gesloten om af te dichten.
4. Schakel het armatuur niet in vóór het einde van de installatie.
5. Bedradingsinstructies: de externe kabel moet worden aangesloten op de aansluitdoos aan de onderkant van de mast. Het IP-beschermingsniveau van de mast moet hoger zijn dan de IP-waarde van het armatuur. Het klemmenblok moet een mogelijke bevestiging voor de kabel hebben. Het klemmenblok moet voldoen aan EN 60998-2-1 of EN 60998-2-2 (specificatie: drie polen, minimaal 250 V en 1,5 mm²).
6. De externe kabel moet minimaal 3 geleiders en een minimale draaddoorsnede van 1,5 mm² hebben. De externe kabel moet voldoen aan de vereisten van 60245 IEC 57.
7. Als de externe kabel beschadigd is, moet de leverancier of een andere gekwalificeerde agent raadplegen voor vervanging om gevaar te voorkomen.
8. Dit armatuur bevat een lichtbron die uitsluitend door de leverancier of door een gemachtigde leverancier voor vervanging wordt verstrekt.



1. The luminaire must not be immersed in water or installed near a fire.
2. The luminaire must be installed by a qualified electrician in accordance with the latest IEEE electrical regulations.
3. Make sure the luminaire closing lid is properly closed to seal and turn hand tight.
4. Do not switch on the luminaire before the end of the installation.
5. Wiring instructions: The external cable must be connected to the connection box at the bottom of the mast. The IP protection level of the mast must be higher than the IP rating of the luminaire. The terminal block must have a possible fixing for the cable. The terminal block must comply with EN 60998-2-1 or EN 60998-2-2 (specification: three poles, at least 250 V and 1,5 mm²).
6. The external cable must have at least 3 conductors and a minimum wire cross section of 1,5 mm². The external cable must meet the requirements of 60245 IEC 57.
7. If the external flexible cable or cord of this luminaire is damaged, it shall be exclusively replaced by the manufacturer or his service agent or a similar qualified person in order to avoid a hazard.
8. The light source contained in this luminaire shall only be replaced by the manufacturer or his service agent or a similar qualified person.



1. Die Leuchte darf nicht in Wasser getaucht oder in der Nähe eines Feuers installiert werden.
2. Die Leuchte muss von einer Elektrofachkraft gemäß den neuesten IEEE-Vorschriften installiert werden.
3. Vergewissern Sie sich, dass der Verschlussclip der Leuchte richtig geschlossen ist, um abzudichten.
4. Schalten Sie die Leuchte erst nach Abschluss der Installation ein.
5. Verdrahtungshinweise: Das externe Kabel muss an der Anschlussbox unten am Mast angeschlossen werden. Die IP-Schutzart des Mastes muss höher sein als die IP-Schutzart der Leuchte. Die Klemmleiste muss eine mögliche Befestigung für das Kabel haben. Die Klemmenleiste muss EN 60998-2-1 oder EN 60998-2-2 entsprechen (Spezifikation: dreipolig, mindestens 250 V und 1,5 mm²).
6. Das externe Kabel muss mindestens drei Leiter und ein minimales Drahtdurchmesser von 1,5 mm². Das externe Kabel muss den Anforderungen von 60245 IEC 57 entsprechen.
7. Wenn das externe Kabel beschädigt ist, muss der Lieferant oder eine andere Person einen qualifizierten Vertreter zum Austausch hinzu ziehen, um Gefahren zu vermeiden.
8. Dieses Gerät enthält eine Lichtquelle, die ausschließlich vom Lieferanten oder von einem autorisierten Vertreter des Lieferanten zum Austausch bereit gestellt wird.



1. Le luminaire ne doit pas être immergé dans l'eau ou installé proximité d'un feu.
2. Le luminaire doit être installé par un électricien qualifié conformément aux dernières réglementations électriques IEEE.
3. Assurez-vous que le clip de fermeture de luminaire est correctement fermé pour assurer l'étanchéité.
4. Ne pas allumer le luminaire avant la fin de l'installation.
5. Instructions de câblage: le câble externe doit être connecté au coffret de connexion placé en pied de mât. Le niveau de protection IP du mât doit être plus élevé que le degré de protection IP de luminaire. Le bornier doit avoir une fixation possible pour le câble. Le bornier doit être conforme à la norme EN 60998-2-1 ou EN 60998-2-2 (spécification: trois pôles, au moins 250 V et 1,5 mm²).
6. Le câble externe doit avoir au moins 3 conducteurs et un minimum de section de fil de 1,5 mm². Le câble externe doit répondre aux exigences de 60245 IEC 57.
7. Si le câble ou le cordon extérieur souple de ce luminaire est endommagé, il doit être remplacé exclusivement par le fabricant ou son agent de maintenance ou toute personne de qualification équivalente, cela afin d'éviter tout risque.
8. La source lumineuse contenue dans ce luminaire ne doit être remplacée que par le fabricant ou son agent de maintenance ou une personne ne de qualification équivalente.