





- NL  Handleiding
- UK  Manual
- DE  Handbuch
- FR  Manuel

LW-Bell



Naam product	LEDs	Vermogen	Kleurtemperatuur	Stroomvoorziening	Installatie hoogte	Gewicht
LW-BELL	8 pcs	8-20W	3000 - 6000K	200-240V ac 50/60Hz	4-6m	9-12 kg
	16 pcs	20-30W			6-8m	
	24 pcs	40-60W			8-10m	
	32 pcs	60-100W			10-12m	



















Name product	LEDs	Power	Light colour	Power supply	Installation Height	Weight
LW-BELL	8 pcs	8-20W	3000 - 6000K	200-240V ac 50/60Hz	4-6m	9-12 kg
	16 pcs	20-30W			6-8m	
	24 pcs	40-60W			8-12m	



Name Produkt	LEDs	Leistung	Farbtemperatur	Stromversorgung	Installationshöhe	Gewicht
LW-BELL	8 pcs	8-20W	3000 - 6000K	200-240V ac 50/60Hz	4-6m	9-12 kg
	16 pcs	20-30W			6-8m	
	24 pcs	40-60W			8-12m	



Nom Produit	LEDs	Puissance	T° de couleur	Alimentation	Hauteur d'installation	Poids
LW-BELL	8 pcs	8-20W	3000 - 6000K	200-240V ac 50/60Hz	4-6m	9-12 kg
	16 pcs	20-30W			6-8m	
	24 pcs	40-60W			8-12m	

 55°C
 IP66
 3-8m

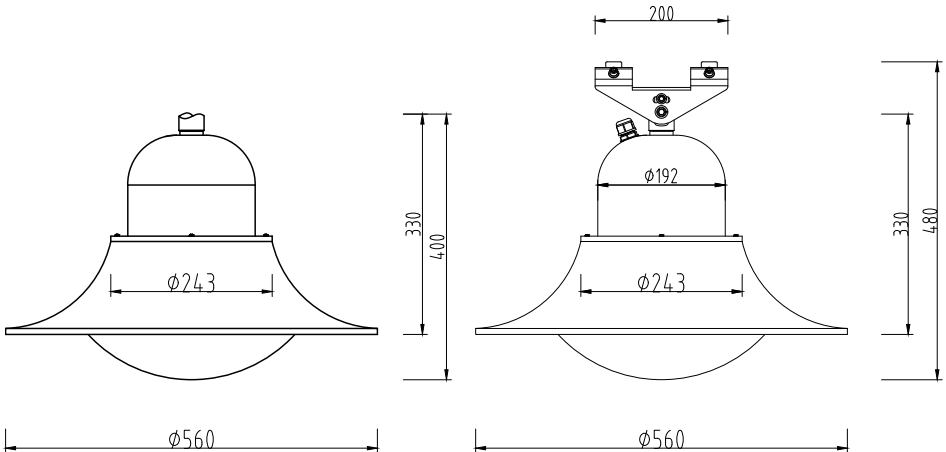

 60-76 mm
 IEC 60598-1
 0,17 m²
 80-20
 9-12 kg
 OS
 CE

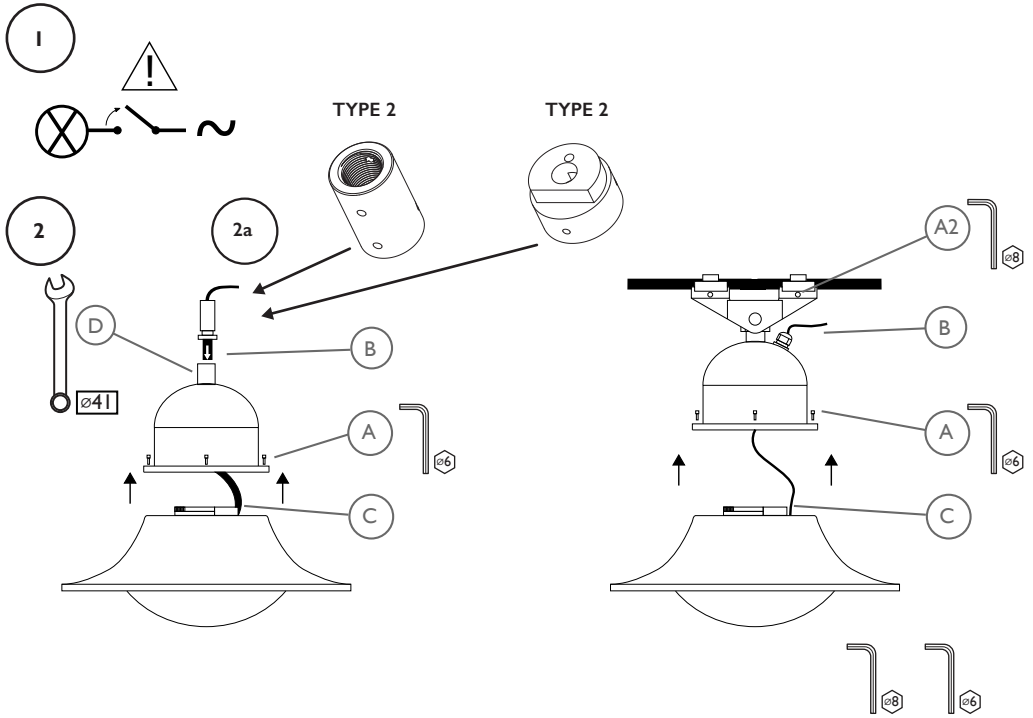
 F
 IK09







Installatie/Installation/Installation/Installation

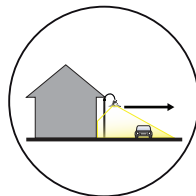

- A Unscrew the four screws
- A2 Mount the luminaire on the wire, tighten the locking plates using the screws
- B Wire trough the cable
- C Connect the cable inside the luminaire
- D Tighting the mounting bolt to fixate the luminaire

3



-  ROAD marking naar de straat gericht
-  Point the ROAD marker towards the street
-  ROAD Markierung auf die Straße richten
-  Dirigez le marqueur ROAD vers la rue

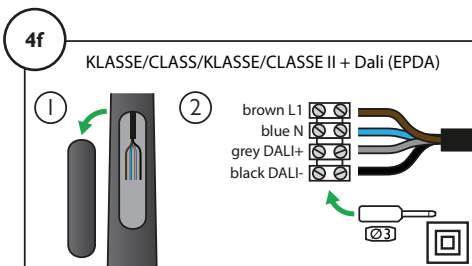
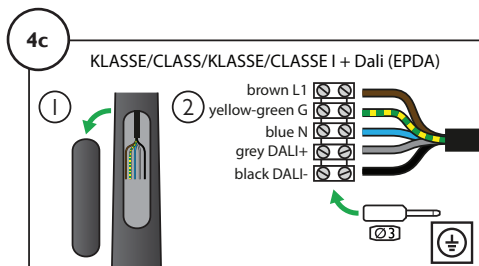
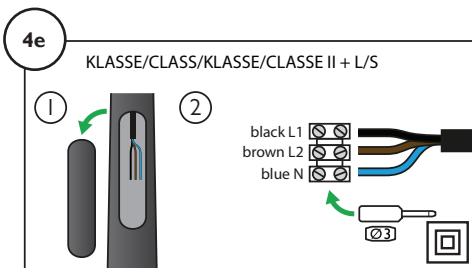
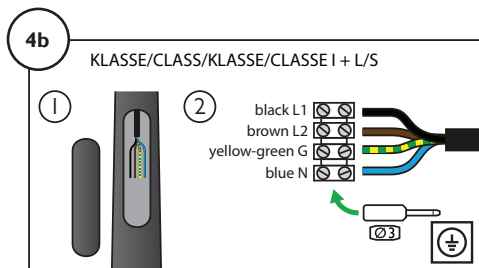
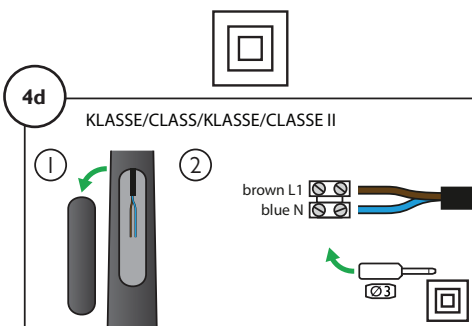
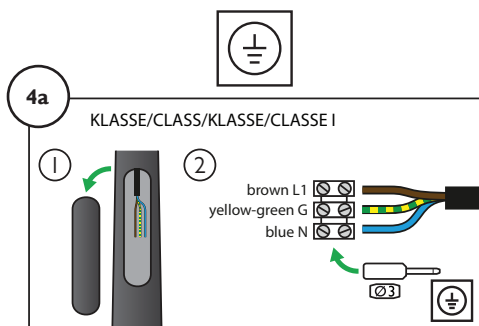



1. Het armatuur mag niet worden ondergedompeld in water of in de buurt van een vuur worden geïnstalleerd.
2. Het armatuur moet worden geïnstalleerd door een gekwalificeerde elektricien in overeenstemming met de nieuwste IEEE elektrische voorschriften.
3. Zorg ervoor dat de sluitop van het armatuur goed is gesloten om af te dichten.
4. Schakel het armatuur niet in vóór het einde van de installatie.
5. Bedragsinstructies: de externe kabel moet worden aangesloten op de aansluitdoos aan de onderkant van de mast.
Het IP-beschermingsniveau van de mast moet hoger zijn dan de IP-waarde van het armatuur. Het klemmenblok moet een mogelijke bevestiging voor de kabel hebben. Het klemmenblok moet voldoen aan EN 60998-2-1 of EN 60998-2-2.
6. De externe kabel is niet vervangbaar.
7. Als de externe kabel beschadigd is, moet de leverancier of een andere gekwalificeerde agent geraadpleegd worden voor vervanging om gevaar te voorkomen.
8. Dit armatuur moet zodanig geïnstalleerd worden dat men niet op een afstand van minder dan 0,406 meter, voor een langere tijd, in de lichtbron kan staren.
9. Dit armatuur bevat een LED lichtbron die uitsluitend door de leverancier of door een gemachtigde leverancier voor vervanging wordt verstrekt.



1. The luminaire must not be immersed in water or installed near a fire.
2. The luminaire shall be installed by a qualified electrician in accordance with the latest IEEE electrical regulations.
3. Make sure the luminaire closing cap is properly closed to seal.
4. Do not switch on the luminaire before the end of the installation.
5. Wiring instructions: The external cable must be connected to the connection box at the bottom of the mast.
The IP protection level of the mast must be higher than the IP rating of the luminaire. The terminal block must have a possible fixing for the cable. The terminal block must comply with EN 60998-2-1 or EN 60998-2-2.
6. The external cable is not replaceable.
7. If the external cable is damaged, the supplier or other must consult a qualified agent for replacement, to avoid any danger.
8. This fixture shall be installed in such a way that it does not allow staring into the light source at a distance of less than 0.406 meters.
9. This fixture contains a LED light source provided solely by the supplier or by an authorized supplier's agent for replacement.



1. Die Leuchte darf nicht in Wasser getaucht oder in der Nähe eines Feuers installiert werden.
2. Die Leuchte muss von einer Elektrofachkraft gemäß den neuesten IEEE-Vorschriften installiert werden.
3. Vergewissern Sie sich, dass die Verschlusskappe der Leuchte richtig geschlossen ist, um abzudichten.
4. Schalten Sie die Leuchte erst nach Abschluss der Installation ein.
5. Verdrahtungshinweise: Das externe Kabel muss an der Anschlussbox (KÜK) unten im Mast angeschlossen werden.
Die IP-Schutzart des Mastes muss höher sein als die IP-Schutzart der Leuchte. Die Klemmleiste muss eine mögliche Befestigung für das Kabel haben. Die Klemmleiste muss EN 60998-2-1 oder EN 60998-2-2 entsprechen.
6. Das Leuchtenkabel ist nicht austauschbar.
7. Wenn das Leuchtenkabel beschädigt ist, muss der Lieferant oder eine andere Person einen qualifizierten Vertreter zum Austausch hinzuziehen, um Gefahren zu vermeiden.
8. Bei der Leuchtenmontage ist es aus Sicherheitsgründen verboten, aus weniger als 0,406 m in die LED Lichtquelle zu schauen.
9. Dieses Gerät enthält eine LED Lichtquelle, die ausschließlich vom Lieferanten oder von einer autorisierten Person des Lieferanten ausgetauscht werden darf.



1. Le luminaire ne doit pas être immergé dans l'eau ou installé à proximité d'un feu.
2. Le luminaire doit être installé par un électricien qualifié conformément aux dernières réglementations électriques IEEE.
3. Assurez-vous que le bouchon de fermeture du luminaire est correctement fermé pour assurer l'étanchéité.
4. Ne pas allumer le luminaire avant la fin de l'installation.
5. Instructions de câblage: le câble externe doit être connecté au coffret de connexion placé en pied de mât. Le niveau de protection IP du mât doit être plus élevé que le degré de protection IP du luminaire. Le bornier doit avoir une fixation disponible pour le câble. Le bornier doit être conforme à la norme EN60998-2-1 ou EN 60998-2-2.
Le câble externe n'est pas remplaçable.
6. Si le câble externe est endommagé, le fournisseur ou autre, doit consulter un agent qualifié pour le remplacement, afin d'éviter tout danger.
7. Ce luminaire doit être installé de manière à ne pas provoquer une vision prolongée vers la source lumineuse à une distance inférieure à 0,406 mètre.
9. Ce luminaire contient une source de lumière LED fournie uniquement par le fournisseur ou par un agent d'un fournisseur agréé pour en assurer le remplacement.

